

TECNOKER

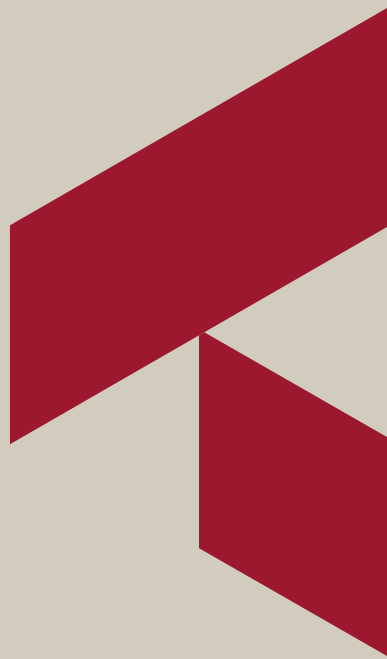

Collections

SURFACES FOR TECHNICAL SPACES



**PORCELAIN TILE SURFACES FOR
TECHNICAL SPACES ENGINEERED
AND MANUFACTURED IN THE U.S.A.**

Index

04	COMPANY
16	ENVIRONMENTS
26	COLLECTIONS
64	TECHNICAL SPECIFICATIONS

01 COMPANY



WHAT WE DO

WE CREATE PORCELAIN TILE SURFACES ENGINEERED TO PERFORM: DURABLE, RELIABLE, AND BUILT TO WITHSTAND PRESSURE DAY AFTER DAY.



INDUSTRIAL_FLOOR: Alaska Natural 12"x12" _WALL: Alaska Natural 8"x8"

WHERE

PROUDLY MADE IN TENNESSEE, OUR TILES ARE BACKED BY A NETWORK THAT REACHES ACROSS THE COUNTRY. PROXIMITY MATTERS. CLARITY MATTERS. BEING THERE MATTERS.



STRENGTH

STRENGTH ISN'T JUST HOW MUCH WEIGHT SOMETHING CAN BEAR. IT'S HOW LONG IT KEEPS DOING ITS JOB WITHOUT CALLING ATTENTION TO ITSELF.

PERFORMANCE



CLEANABILITY

In technical environments, hygiene is a foundational requirement, not an after-thought. TecnoKER surfaces are designed to resist staining and to facilitate quick, effective maintenance.

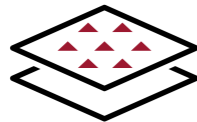

SLIP RESISTANCE

In demanding environments safety comes first. TecnoKER's surfaces are developed with certified slip resistance, referenced in ANSI A326.3 and ANSI A137.1



ACID RESISTANCE

A surface that withstands repeated chemical exposure reduces downtime, maintenance costs, and the risk of early replacement. TecnoKER tiles are engineered for these conditions and are aligned with ASTM C650, the test used to assess resistance to acids and chemical agents.



BREAKING STRENGTH

TecnoKER products are engineered to deliver high breaking strength, as defined by ASTM C648 and ANSI A137.1. These standards measure the force required to break a tile, a parameter that is critical in automotive workshops, industrial plants, loading areas, and high-traffic back-of-house zones.

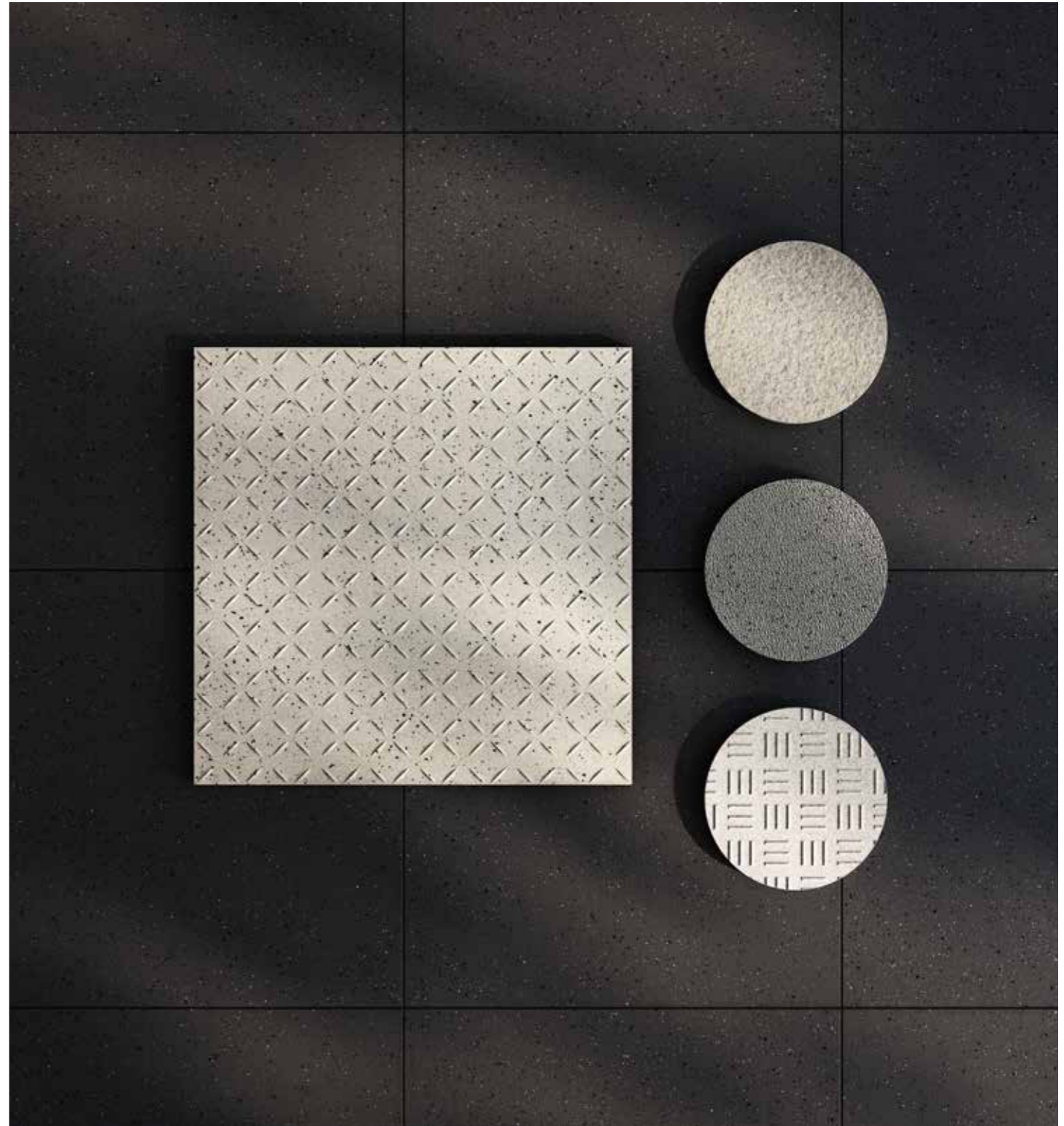

HOW WE DO IT

WE CHOSE TO KEEP THINGS SIMPLE: FOUR SIZES, HEAVY-DUTY PERFORMANCE, ZERO DISTRACTIONS.

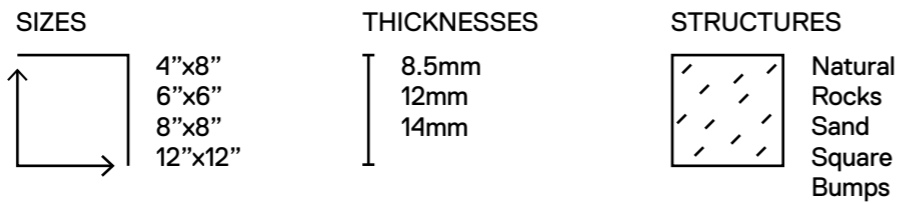

WHY?

A FOCUSED SCOPE DESIGNED TO BE TIMELESS AND TESTED TO ENDURE: PRECISION WITHOUT COMPLEXITY.

OUR IDEA

THIS IS OUR IDEA OF DESIGN: EFFICIENT, GROUNDED, AND BUILT TO LAST.



OUR PORCELAIN TILES ARE MANUFACTURED IN THE UNITED STATES, TESTED AND CERTIFIED ACCORDING TO RECOGNISED NATIONAL AND INTERNATIONAL STANDARDS.

SLIP RESISTANCE

Slip resistance is measured through DCOF testing to ANSI A326.3, which quantifies surface performance under controlled conditions. The standard provides reference values for wet environments, supporting safety-driven specifications. TecnoKER products are certified according to ANSI A326.3 and are developed to provide reliable grip in spaces exposed to water, grease, and frequent cleaning.

WATER ABSORPTION

Water absorption is tested to ASTM C373, measuring the percentage of water absorbed by the tile body under vacuum conditions. Low absorption supports dimensional stability and hygienic performance in wet areas.

TecnoKER porcelain tiles show very low absorption values (e.g., 0.2% reported for 12"x12"), reinforcing suitability for demanding technical environments.

BREAKING STRENGTH

Breaking strength is verified through ASTM C648, referenced in ANSI A137.1, measuring the force required to break a tile under load. This value indicates resistance to impacts, rolling loads, and concentrated stress.

TecnoKER products are tested to ASTM C648 and engineered to withstand mechanical pressure typical of workshops, production areas, and heavy-traffic spaces.

CHEMICAL RESISTANCE

Chemical resistance is tested to ISO 10545-13, exposing surfaces to acids, bases, and common chemical agents, then classifying visible effects.

TecnoKER products achieved "A – No Visible Effect" in testing, confirming resistance to routine sanitizing agents and supporting long-term surface stability in industrial and food environments.

STAIN RESISTANCE

Stain resistance is evaluated according to ISO 10545-14, applying staining agents and verifying removal through defined cleaning procedures.

In testing, stains such as olive oil and iodine were removed with the simplest procedure (Class 5). TecnoKER surfaces are certified to support effective cleaning in operational environments.

FROST RESISTANCE

Freeze–thaw resistance is tested to ASTM C1026, cycling saturated specimens through repeated freezing and thawing, then verifying surface integrity.

After 300 cycles, tested samples showed no visible damage. TecnoKER products are certified to maintain structural stability in environments exposed to temperature variation and moisture.

CARE & MAINTENANCE



Maintenance guidelines define routine and deep cleaning procedures using the FILA system. Neutral cleaning is recommended for daily care, with defined dilutions for periodic deep cleaning.

TecnoKER porcelain tiles are designed to withstand frequent cleaning cycles while maintaining technical performance and surface integrity over time.

BUILT FOR REAL ENVIRONMENTS

TECNOKER PORCELAIN TILES ARE ENGINEERED TO PERFORM ACROSS ALL COMMERCIAL ENVIRONMENTS, COMBINING COORDINATED FORMATS, MULTIPLE THICKNESS OPTIONS, SPECIALIZED SURFACE TEXTURES, AND PURPOSE-BUILT ACCESSORIES TO MEET A WIDE RANGE OF TECHNICAL DEMANDS.

One simplified program that supports a broad variety of installations. Sizes help manage different load conditions, thicknesses support different mechanical stresses, and surface structures align with specific slip-resistance needs.

Special pieces like cove bases, step treads, corners, and trims, maintain continuity across edges and transitions, supporting hygiene and simplifying maintenance. The same technical logic applies across multiple environments, from food and wet areas to workshops, back-of-house retail, and controlled spaces.



02

ENVIRONMENTS



FACTORY_FLOOR: North Dakota Natural 8"x8" / North Dakota Bumps 8"x8"
WALL: North Dakota Natural 12"x12" / North Dakota Natural Cove Base Flat Top 6"x12"

INDUSTRIAL KITCHENS**HIGH TRAFFIC
AND STRICT HYGIENE
& SAFETY STANDARDS**

Commercial kitchens operate under constant pressure: water, grease, food residues, and rapid cleaning cycles define daily operations. Floors must provide reliable slip resistance, support equipment loads, and maintain cleanability without surface degradation. Performance consistency is essential to ensure hygiene compliance, worker safety, and uninterrupted service.

**WORKSHOPS****BUILT FOR IMPACT
AND MECHANICAL STRESS.**

Workshops and light manufacturing spaces expose floors to tools, machinery, rolling loads, and chemical agents. Surfaces must deliver high breaking strength, resistance to oils and contaminants, and durability under repeated point loads. Long-term performance reduces maintenance interruptions and protects operational continuity.



INDUSTRIAL_FLOOR: Alaska Bumps 12"x12"

PUBLIC FACILITIES

DURABILITY FOR HIGH-TRAFFIC COMMUNITY SPACES.

Schools, institutional buildings, and public facilities demand floors that withstand constant foot traffic, daily cleaning, and long-term wear. Surfaces must balance durability, ease of maintenance, and predictable slip resistance to ensure safety and reliability in shared environments.

WET AREAS

SAFETY AND HYGIENE IN MOISTURE-PRONE ENVIRONMENTS.

Locker rooms, laundry facilities, and service wet areas require surfaces that manage continuous exposure to water and cleaning agents. Slip resistance remains critical, while proper detailing and compatible special pieces support hygienic transitions and ease of maintenance. Performance must remain stable under frequent washing and heavy foot traffic.



INDUSTRIAL_FLOOR: Arkansas Natural 6"x6" / Arkansas Natural Stair Tread 12"x12" / Arkansas Natural Bullnose 3"x12"

LABORATORIES

CONTROLLED ENVIRONMENTS DEMAND CONTROLLED SURFACES.

Medical, biomedical, and research laboratories require surfaces that maintain chemical resistance, stability, and cleanability. Exposure to sanitizing agents and controlled cleaning protocols make acid resistance and surface integrity essential. Consistent performance supports compliance and reduces risk in sensitive environments.



INDUSTRIAL_FLOOR: Alaska Natural 12"x12"



INDUSTRIAL_FLOOR: Arizona Rocks 8"x8"

FOOD PROCESSING PLANTS

PERFORMANCE UNDER INDUSTRIAL HYGIENE STANDARDS.

Wineries, dairies, meat processing facilities, and beverage plants operate with strict sanitation protocols and frequent chemical exposure. Floors must resist acids, organic residues, and intensive washdowns while maintaining slip resistance and structural strength. Reliable performance supports regulatory compliance and continuous production.



INDUSTRIAL_FLOOR: Iowa Natural 6"x6" / Arkansas Natural 6"x6"

MALL ENVIRONMENTS & GROCERIES

OPERATIONAL RELIABILITY BEHIND THE SCENES.

Food courts, grocery stores, and mall back-of-house areas experience constant traffic, carts, spills, and cleaning cycles. Surfaces must withstand rolling loads and daily maintenance while preserving safety standards. Durability and predictable grip reduce liability and support long-term facility management.

LOGISTICS & PRODUCTION PLANTS

ENGINEERED FOR MOVEMENT AND LOAD.

Distribution centers and production facilities expose floors to forklifts, pallet jacks, storage systems, and concentrated mechanical stress. High breaking strength, surface stability, and resistance to industrial cleaning agents ensure durability under sustained operational pressure.



INDUSTRIAL_FLOOR: Iowa Natural 8"x8"

03

COLLECTIONS

28

INDUSTRIAL

46

FACTORY

COLLECTION

INDUSTRIAL

**BUILT ON A COMPACT,
PERFORMANCE-DRIVEN
COLOR RANGE.
DESIGNED FOR DEMANDING
TECHNICAL ENVIRONMENTS.**

The palette is consistent and controlled, with a distinctive mineral texture enriched by fine dark aggregates that reinforce its technical character.

The surface structure supports grip, durability, and visual stability under heavy use. Industrial is developed for spaces where mechanical stress, frequent cleaning, and operational continuity define the floor's role. The result is a surface that maintains performance over time while preserving a clear, functional aesthetic.

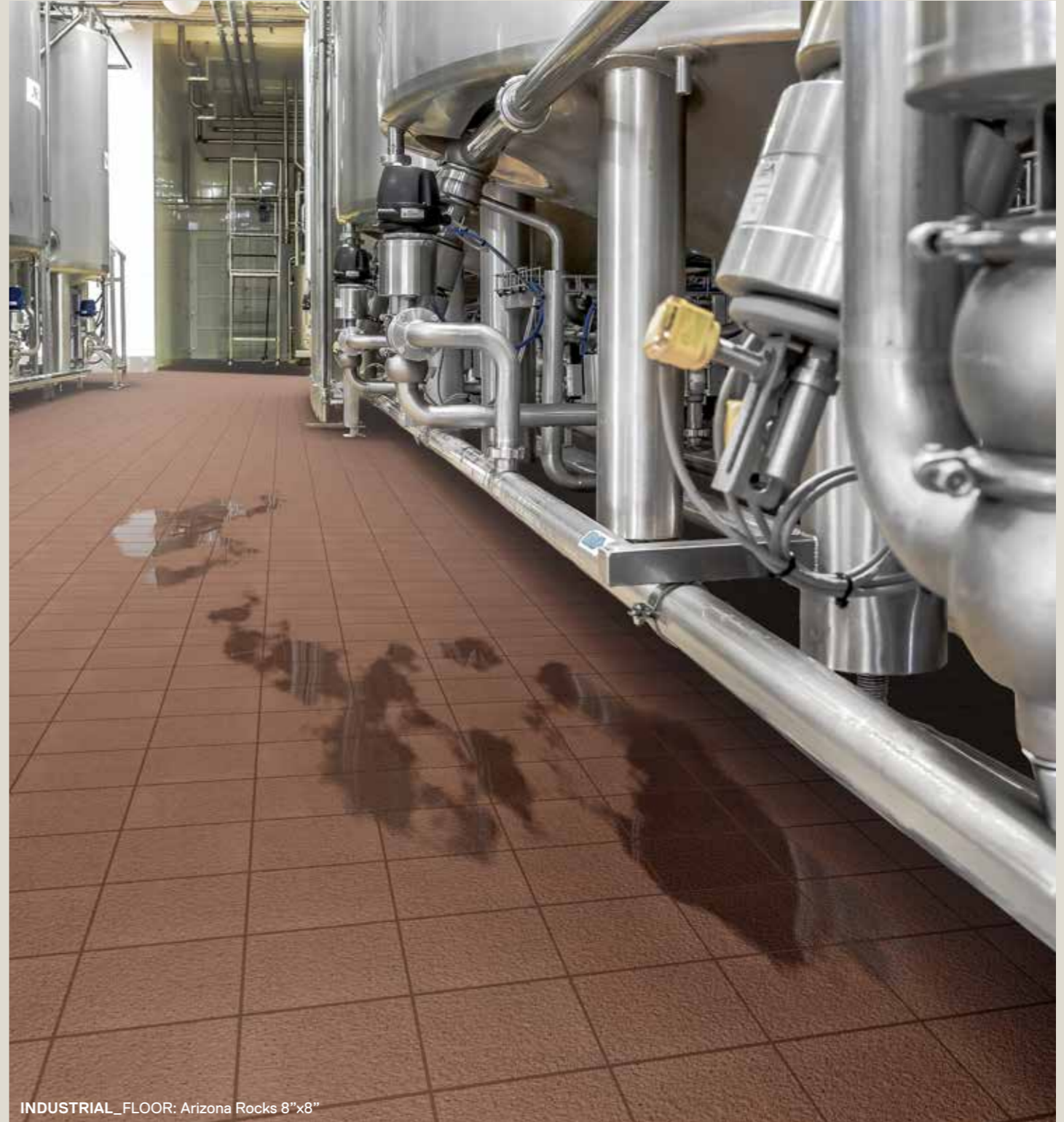

INDUSTRIAL_FLOOR: Arizona Rocks 8"x8"

INDUSTRIAL

COLOR RANGE



ALASKA

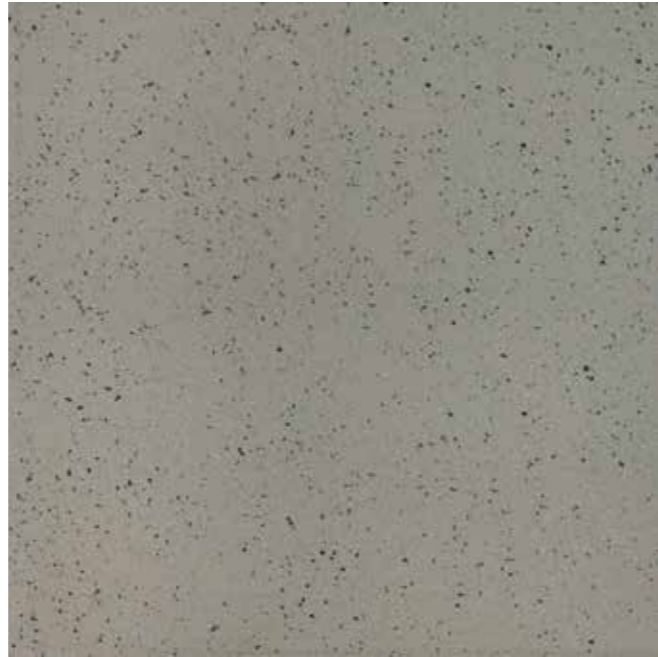

IOWA

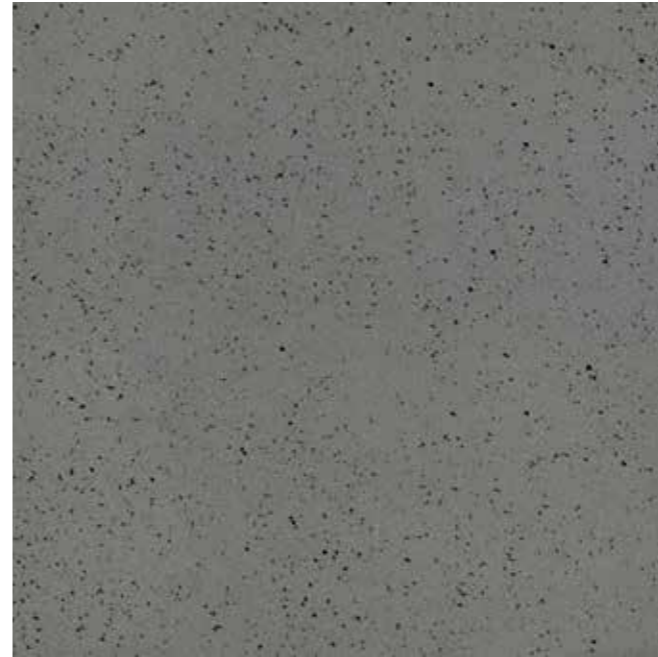

ARKANSAS



UTAH



FLORIDA



ARIZONA



GEORGIA

**CUSTOM COLORS AND GRAPHICS
ARE AVAILABLE UPON REQUEST
FOR QUALIFIED PROJECTS.**

Tecnoker is proud to offer fully **customized solutions**, because we understand that every project deserves a personal touch. Our custom porcelain tile program is accessible and flexible, with minimum orders starting at just 1.000 square feet.

INDUSTRIAL

ALASKA

SIZES

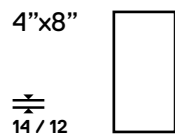
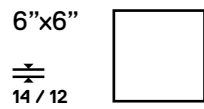
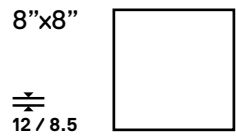
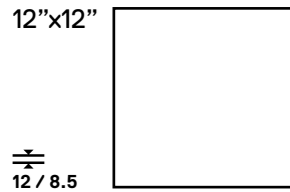

NATURAL

AVAILABLE IN ALL SIZES

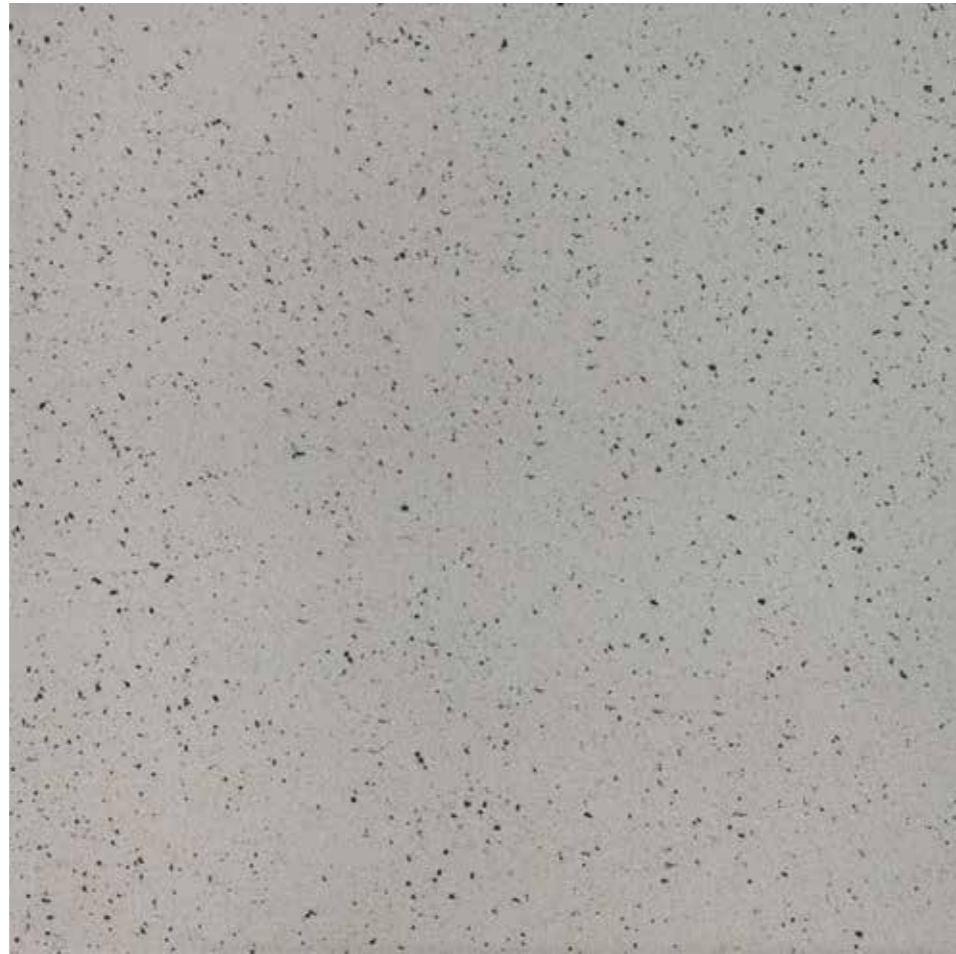

STRUCTURES

AVAILABLE FOR SIZES 12"x12" AND 8"x8"



SAND

ROCKS

SQUARE

BUMPS

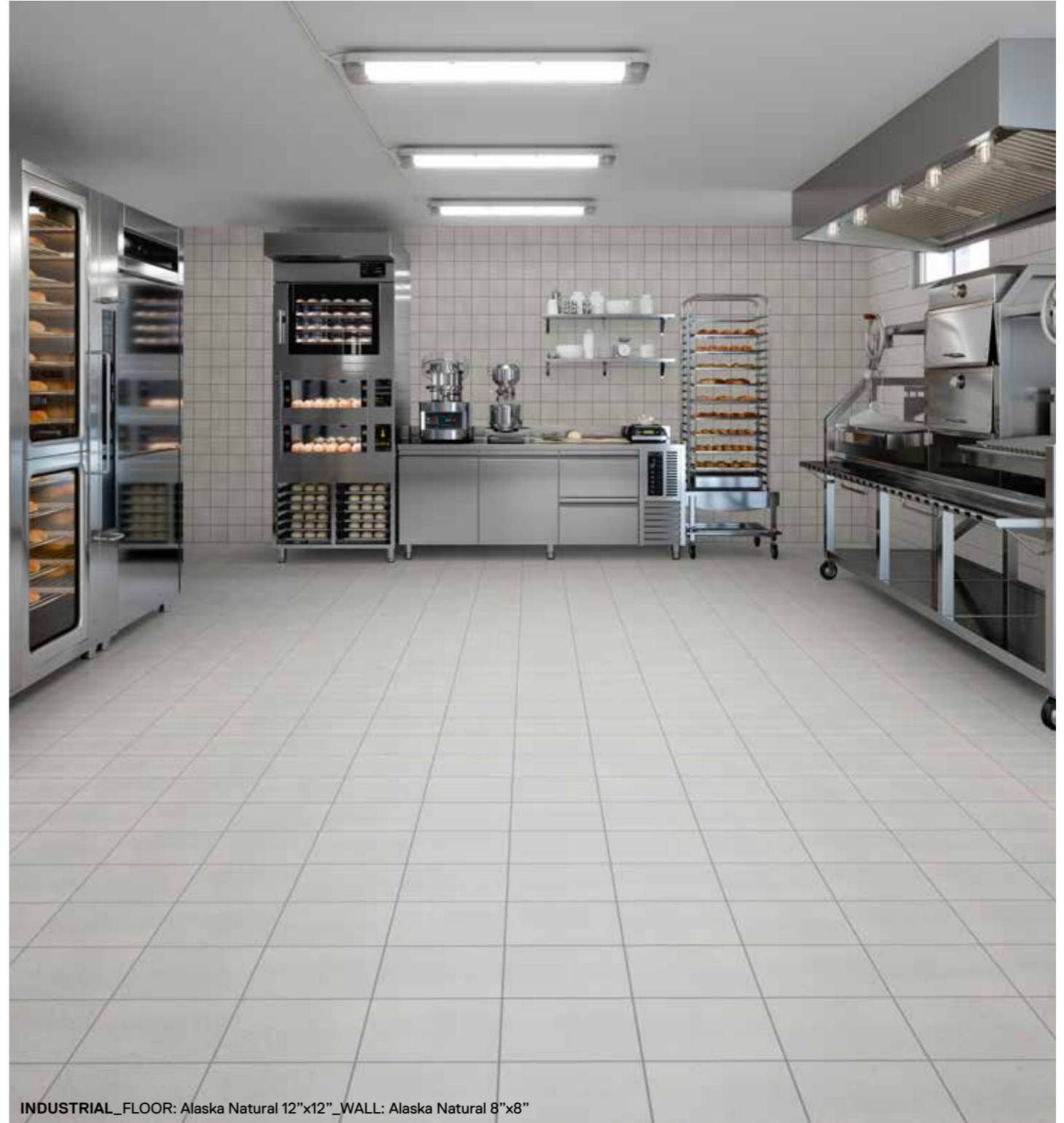

INDUSTRIAL_FLOOR: Alaska Natural 12"x12" _WALL: Alaska Natural 8"x8"

INDUSTRIAL

IOWA

SIZES

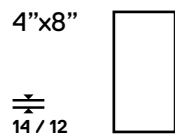
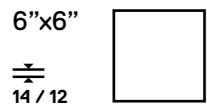
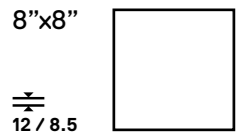
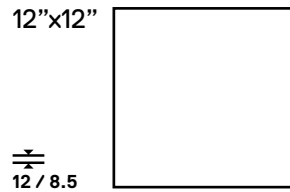

NATURAL

AVAILABLE IN ALL SIZES

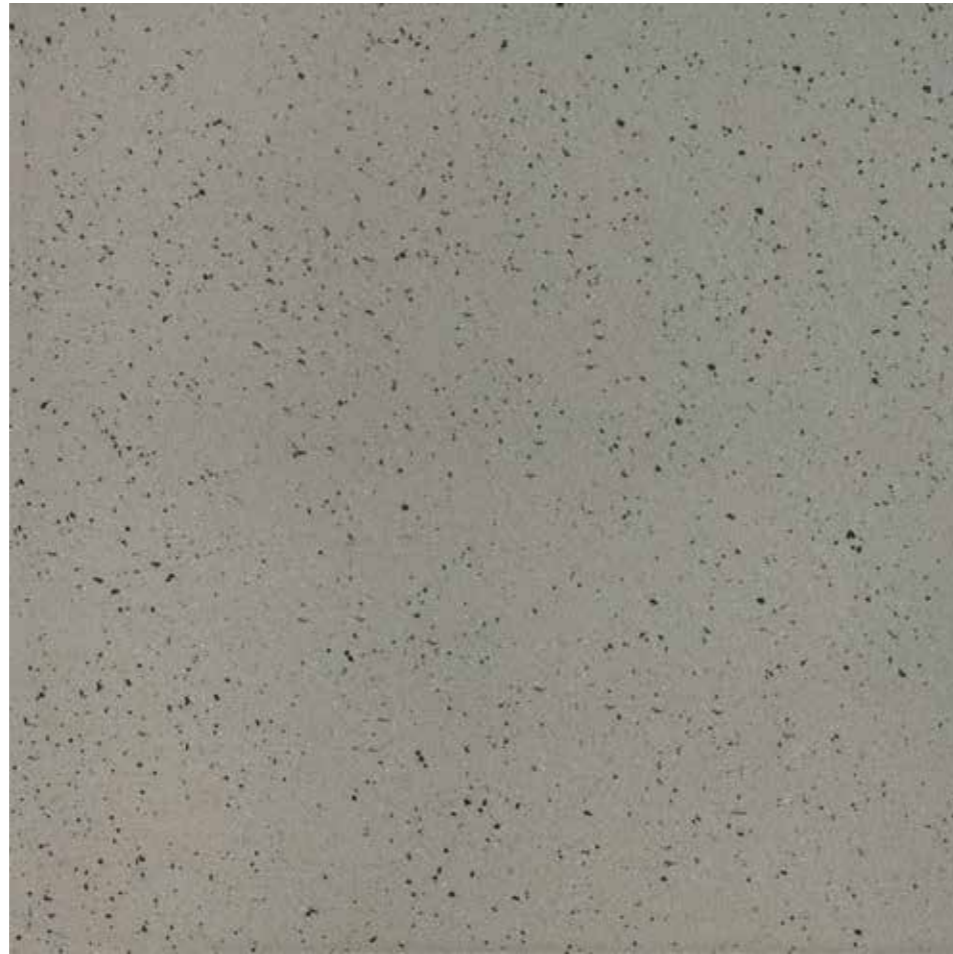

STRUCTURES

AVAILABLE FOR SIZES 12"x12" AND 8"x8"

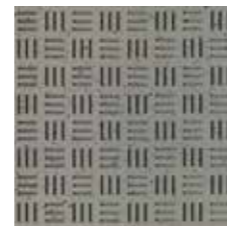

SAND

ROCKS

SQUARE

BUMPS

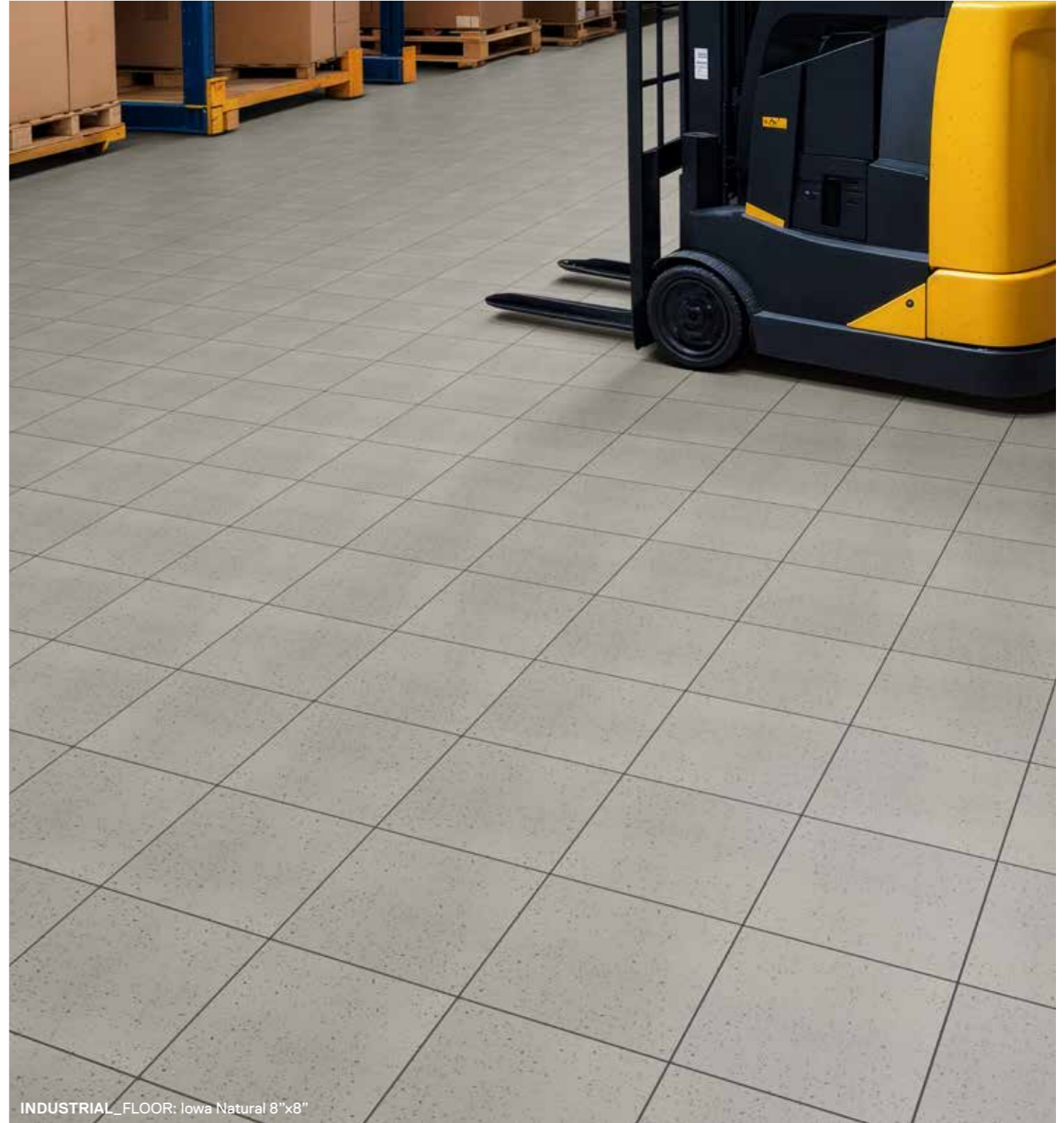

INDUSTRIAL_FLOOR: Iowa Natural 8"x8"

INDUSTRIAL

FLORIDA

SIZES

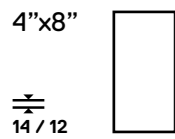
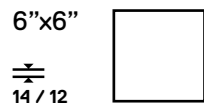
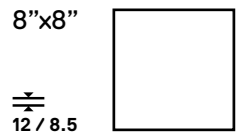

NATURAL

AVAILABLE IN ALL SIZES



STRUCTURES

AVAILABLE FOR SIZES 12"x12" AND 8"x8"

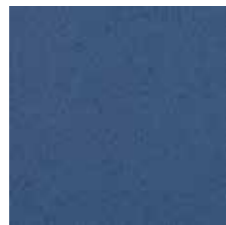

SAND

ROCKS

SQUARE

BUMPS



INDUSTRIAL_FLOOR: Florida Sand 12"x12" / Florida Natural Cove Base Flat Top 6"x12" / Florida Natural Outside/Inside Corner Flat Top 1"x6"

INDUSTRIAL

ARIZONA

SIZES

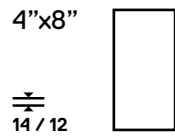
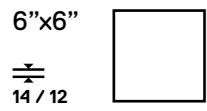
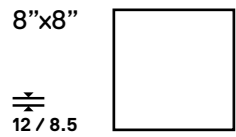
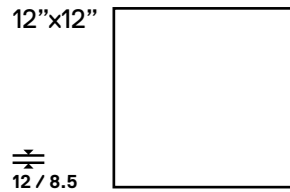

NATURAL

AVAILABLE IN ALL SIZES



STRUCTURES

AVAILABLE FOR SIZES 12"x12" AND 8"x8"

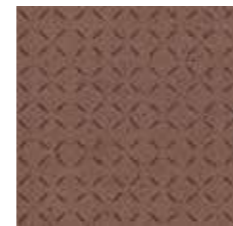
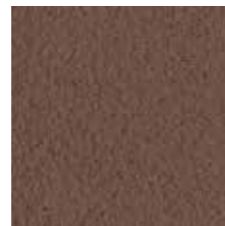

SAND

ROCKS

SQUARE

BUMPS



INDUSTRIAL_FLOOR: Arizona Natural 12"x12"

INDUSTRIAL

ARKANSAS

SIZES

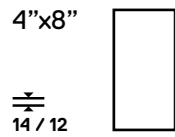
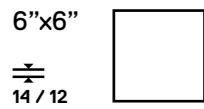
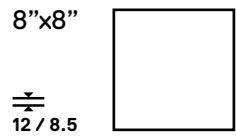
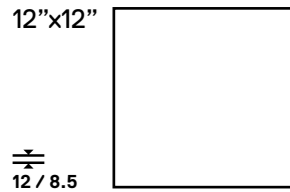

NATURAL

AVAILABLE IN ALL SIZES

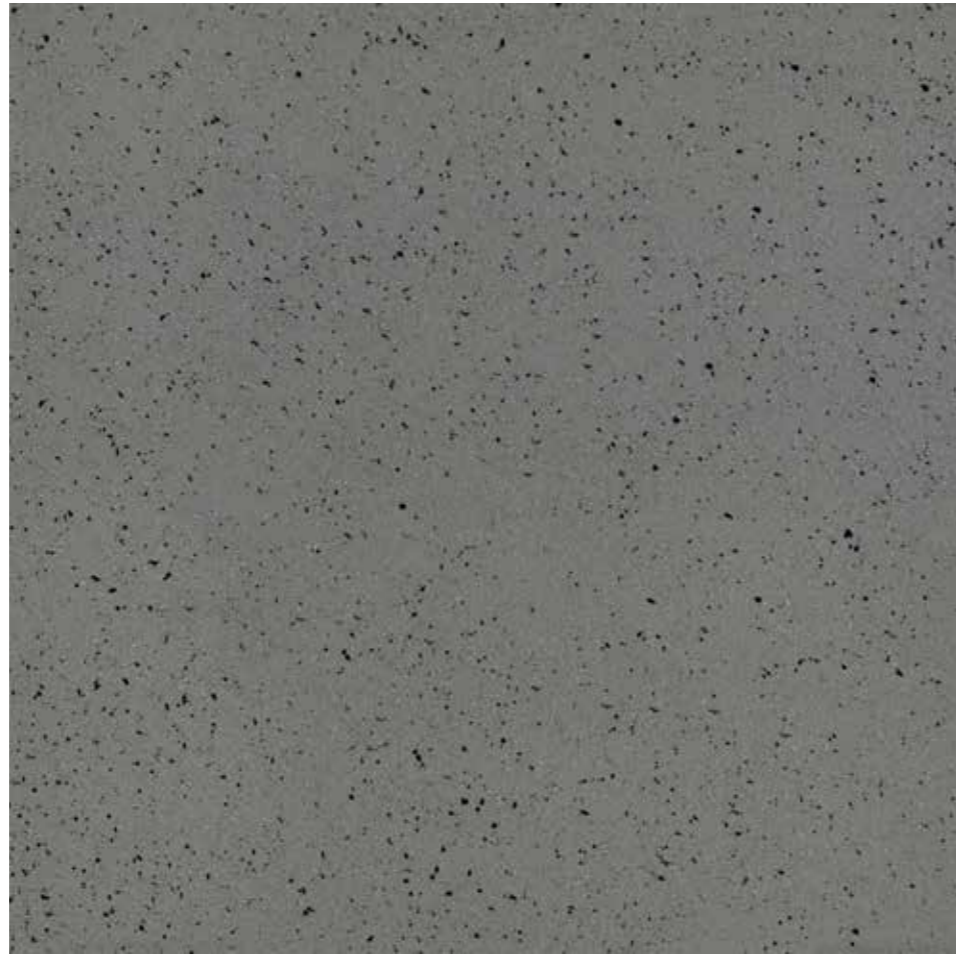

STRUCTURES

AVAILABLE FOR SIZES 12"x12" AND 8"x8"

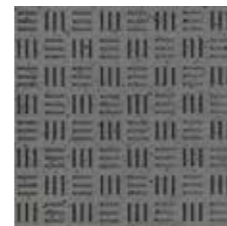

SAND

ROCKS

SQUARE

BUMPS



INDUSTRIAL_FLOOR: Arkansas Natural 8"x8"

INDUSTRIAL

UTAH

SIZES

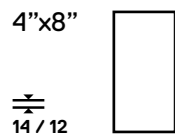
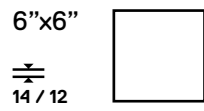
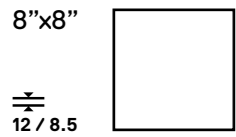
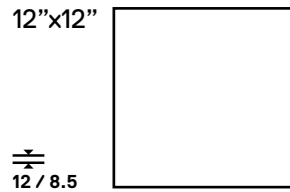

NATURAL

AVAILABLE IN ALL SIZES



STRUCTURES

AVAILABLE FOR SIZES 12"x12" AND 8"x8"

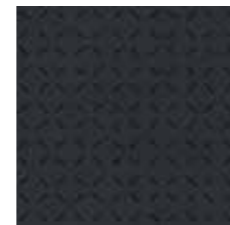
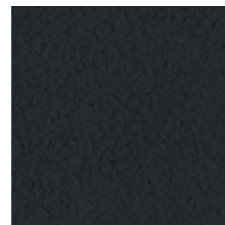
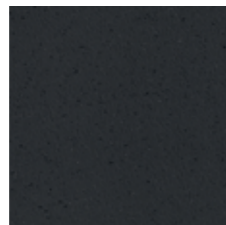

SAND

ROCKS

SQUARE

BUMPS



INDUSTRIAL_FLOOR: Utah Natural 12"x12"

INDUSTRIAL

GEORGIA

SIZES

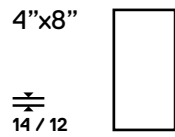
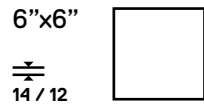
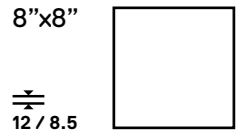
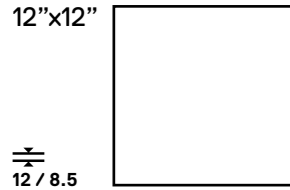

NATURAL

AVAILABLE IN ALL SIZES



STRUCTURES

AVAILABLE FOR SIZES 12"x12" AND 8"x8"

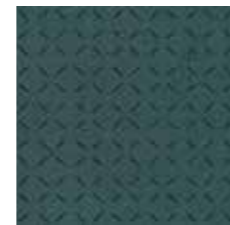
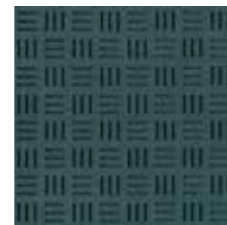
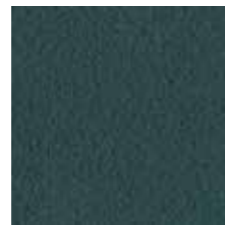
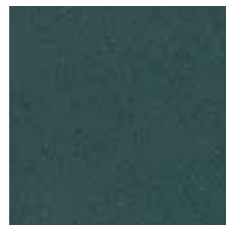

SAND

ROCKS

SQUARE

BUMPS

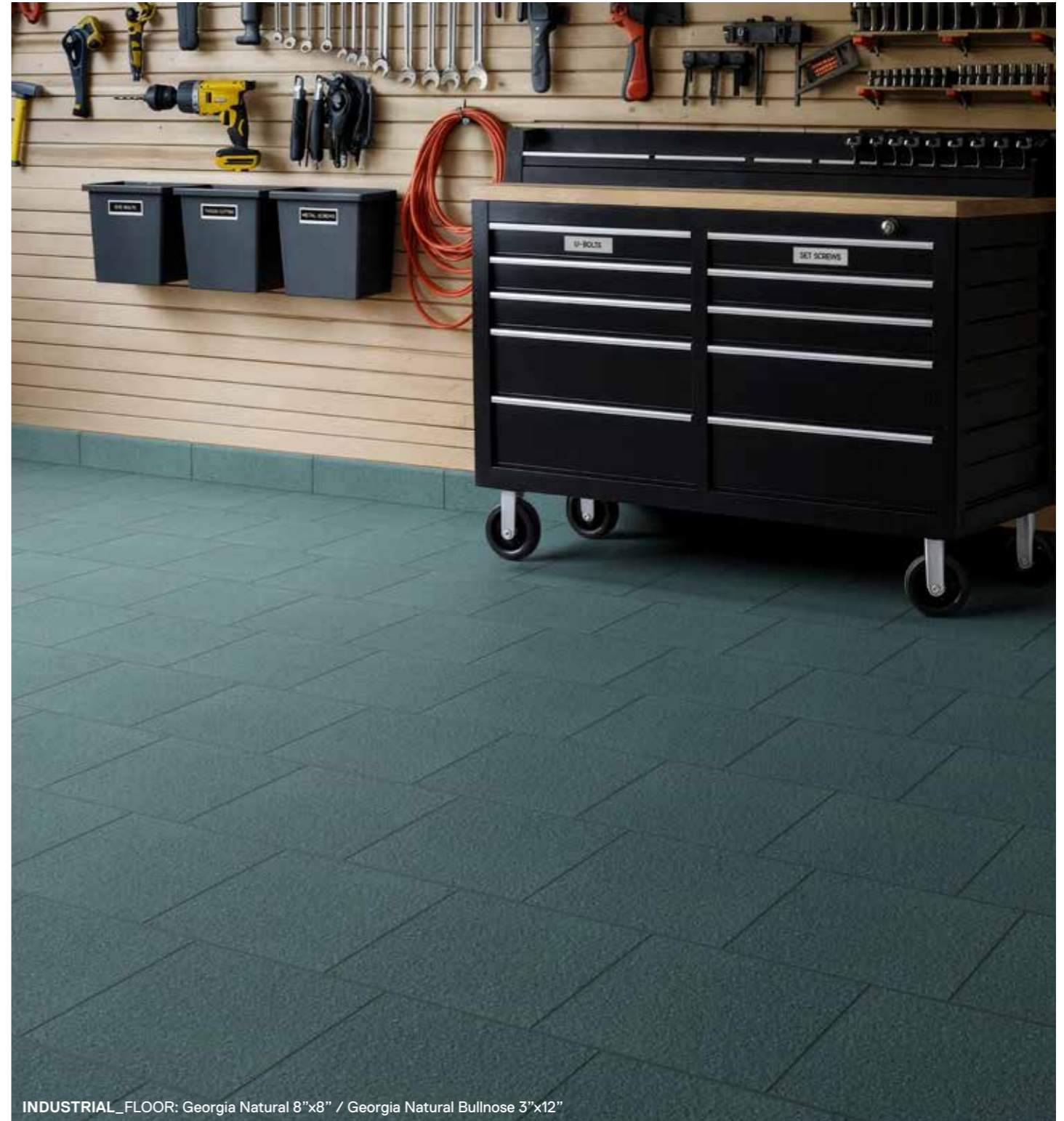

INDUSTRIAL_FLOOR: Georgia Natural 8"x8" / Georgia Natural Bullnose 3"x12"

COLLECTION

FACTORY

FACTORY IS A FOCUSED COLOR RANGE DEFINED BY A COMPACT, EVEN TEXTURE AND A CLEAR FUNCTIONAL AESTHETIC.

The surface is designed for technical spaces where cleanliness, safety, and long-term durability drive material selection.

Across formats and thicknesses, Factory supports predictable performance under heavy traffic, frequent maintenance, and day-to-day operational stress. It is built to stay stable over time, with specifications that remain clear, verifiable, and consistent in real working conditions.



FACTORY_FLOOR: South Dakota Natural 6"x6" / South Dakota Natural Stair Tread 12"x12"
South Dakota Natural Bullnose 3"x12" / South Dakota Natural 12"x12"

FACTORY

COLOR RANGE

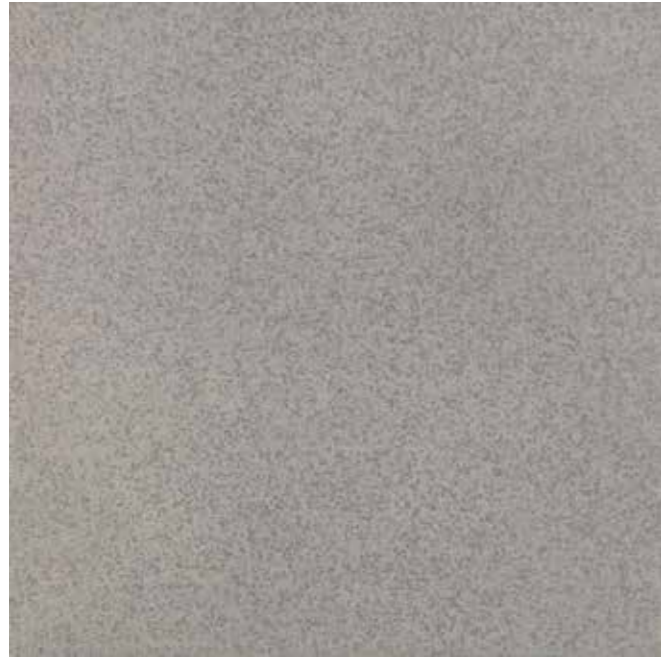

NORTH DAKOTA



SOUTH DAKOTA

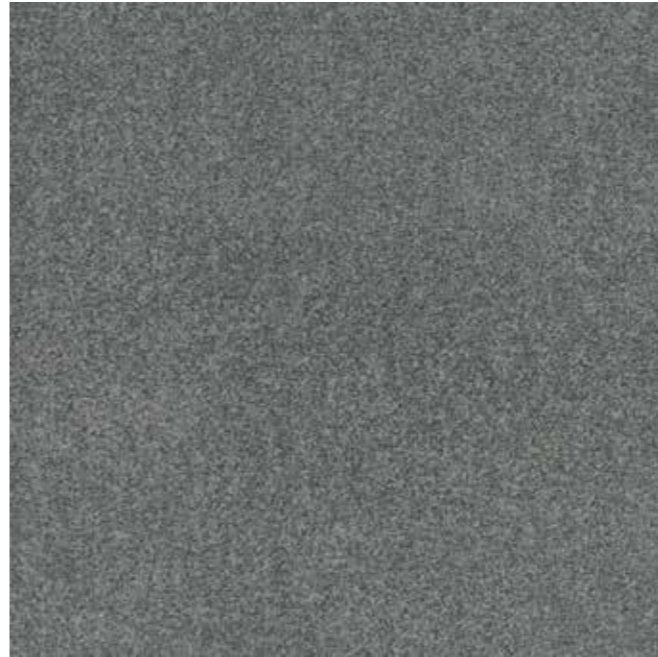

OREGON



ILLINOIS



CALIFORNIA



NEW MEXICO



COLORADO

**CUSTOM COLORS AND GRAPHICS
ARE AVAILABLE UPON REQUEST
FOR QUALIFIED PROJECTS.**

Tecnoker is proud to offer fully **customized solutions**, because we understand that every project deserves a personal touch. Our custom porcelain tile program is accessible and flexible, with minimum orders starting at just 1.000 square feet.

FACTORY

NORTH DAKOTA

SIZES

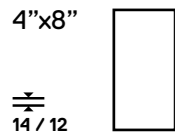
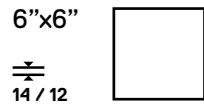
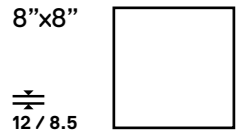
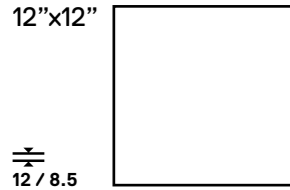

NATURAL

AVAILABLE IN ALL SIZES



STRUCTURES

AVAILABLE FOR SIZES 12"x12" AND 8"x8"

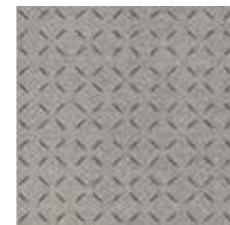
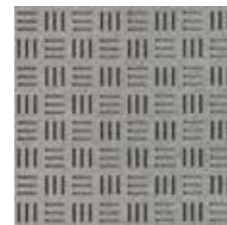

SAND

ROCKS

SQUARE

BUMPS



FACTORY_FLOOR: North Dakota Square 12"x12"

FACTORY

SOUTH DAKOTA

SIZES

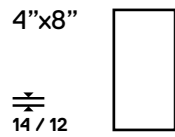
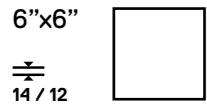
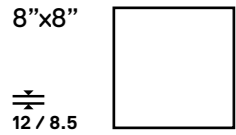
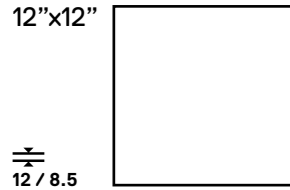

NATURAL

AVAILABLE IN ALL SIZES



STRUCTURES

AVAILABLE FOR SIZES 12"x12" AND 8"x8"

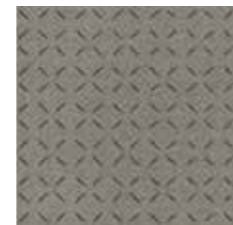

SAND

ROCKS

SQUARE

BUMPS

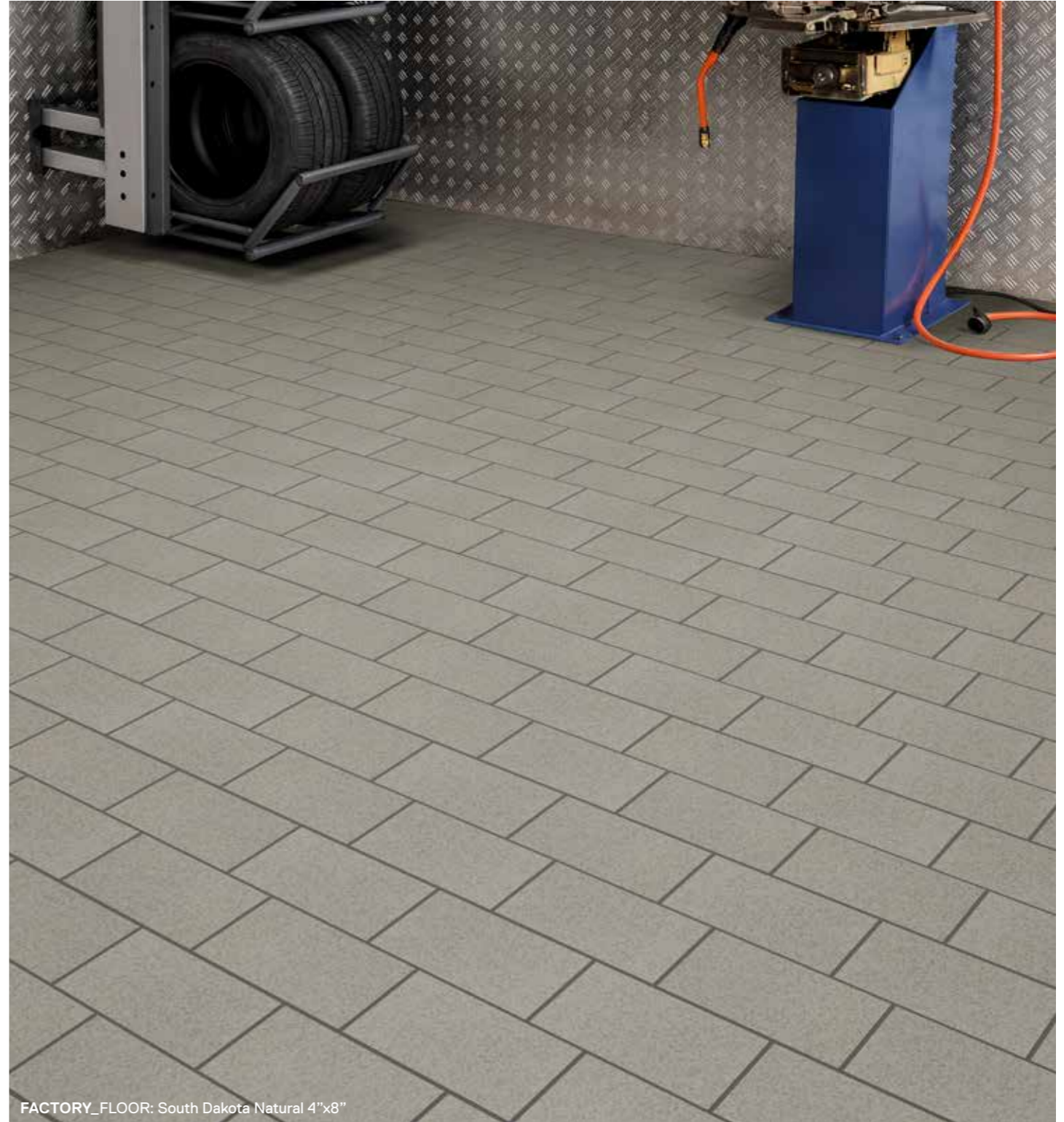

FACTORY_FLOOR: South Dakota Natural 4"x8"

FACTORY

CALIFORNIA

SIZES

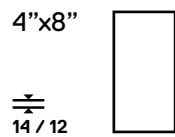
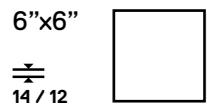
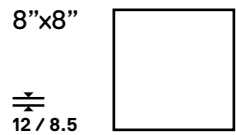
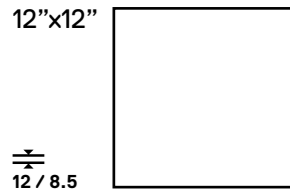

NATURAL

AVAILABLE IN ALL SIZES

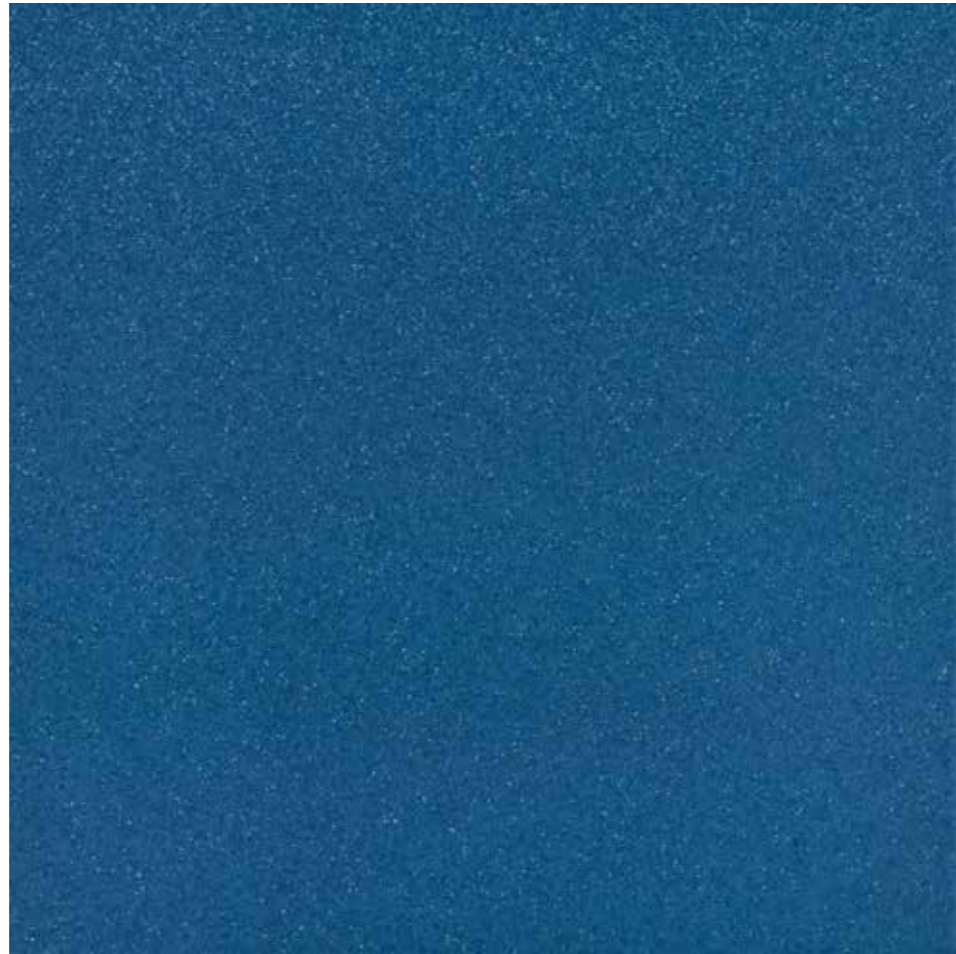

STRUCTURES

AVAILABLE FOR SIZES 12"x12" AND 8"x8"



SAND

ROCKS

SQUARE

BUMPS

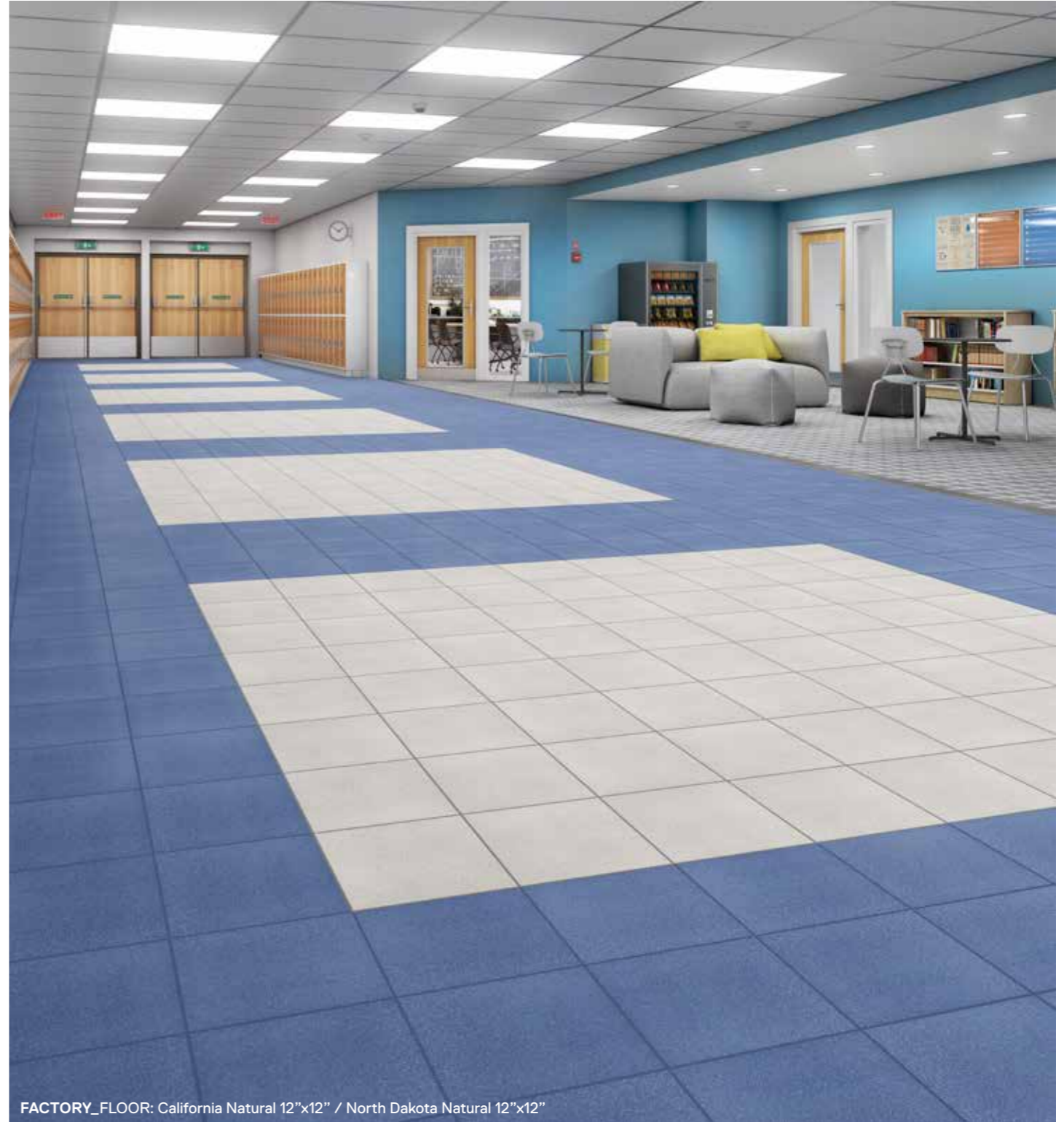

FACTORY_FLOOR: California Natural 12"x12" / North Dakota Natural 12"x12"

FACTORY

NEW MEXICO

SIZES

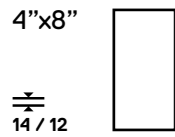
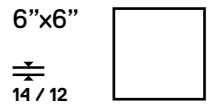
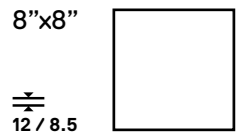
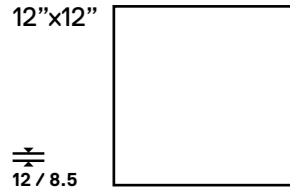

NATURAL

AVAILABLE IN ALL SIZES



STRUCTURES

AVAILABLE FOR SIZES 12"x12" AND 8"x8"

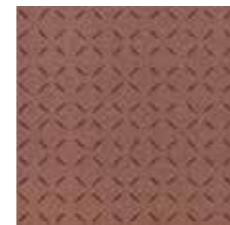
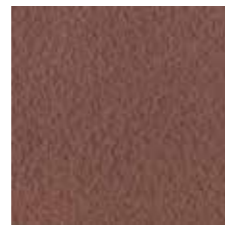

SAND

ROCKS

SQUARE

BUMPS

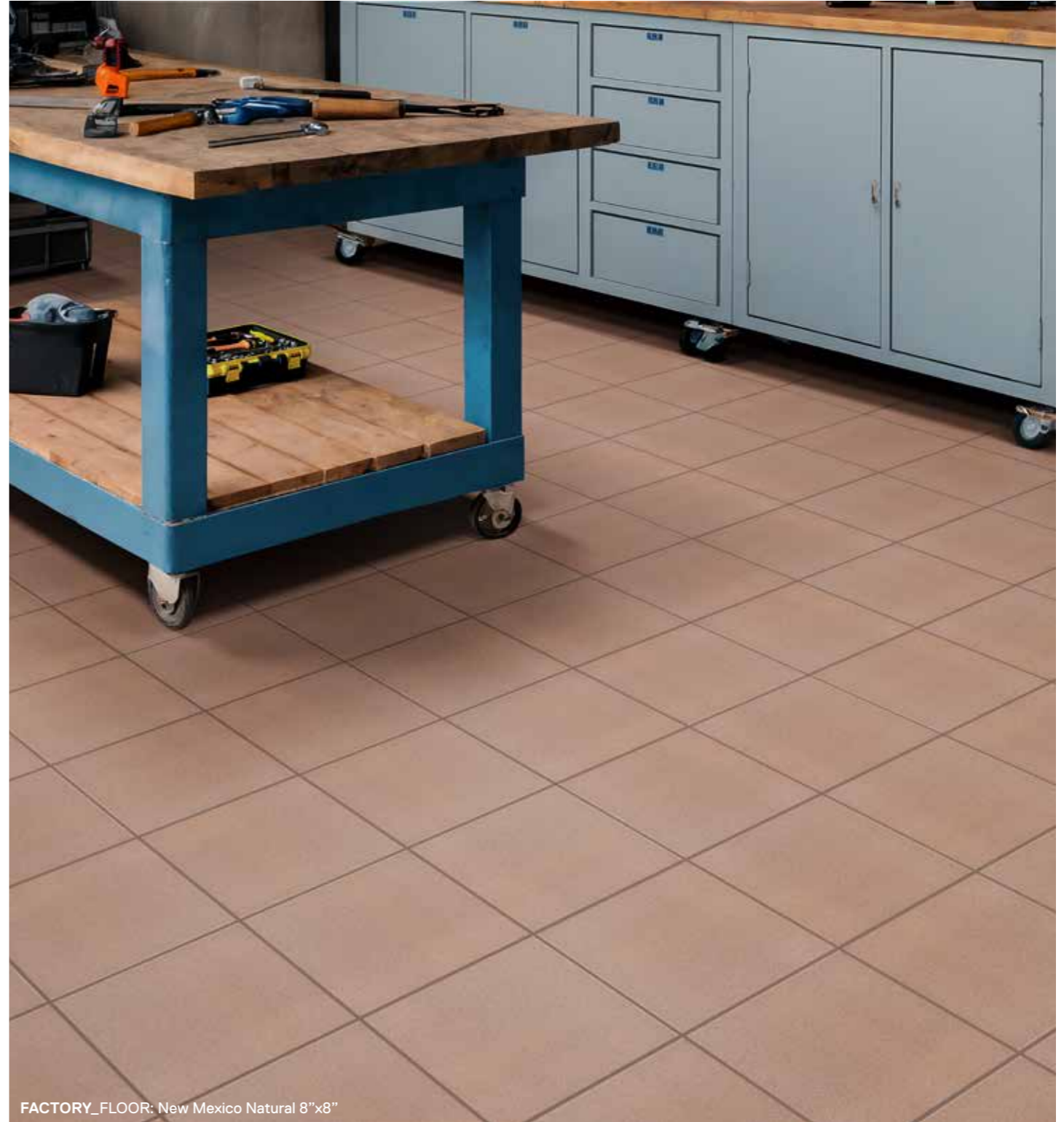

FACTORY_FLOOR: New Mexico Natural 8"x8"

FACTORY

SIZES

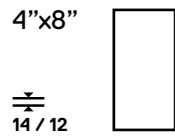
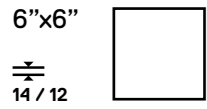
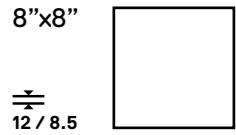
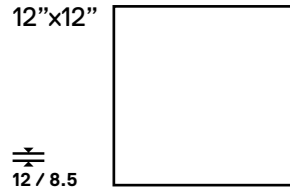

OREGON

NATURAL

AVAILABLE IN ALL SIZES

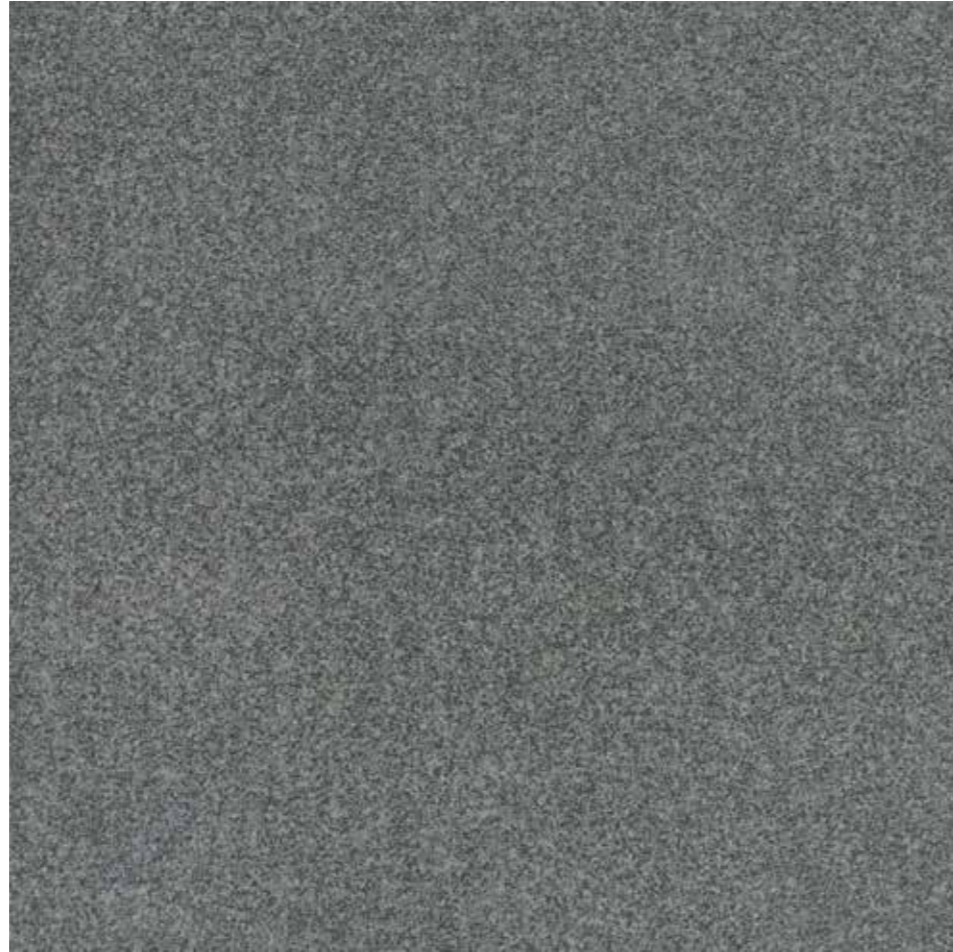

STRUCTURES

AVAILABLE FOR SIZES 12"x12" AND 8"x8"

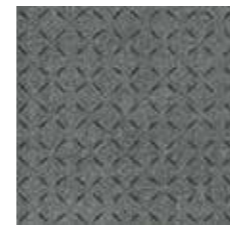
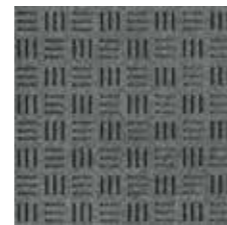

SAND

ROCKS

SQUARE

BUMPS



FACTORY_FLOOR: Oregon Natural 12"x12"

FACTORY

SIZES

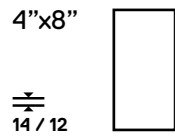
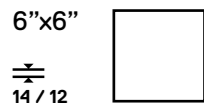
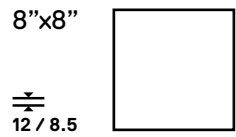
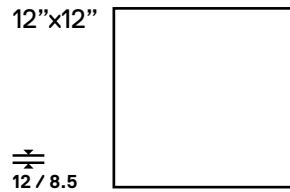

ILLINOIS

NATURAL

AVAILABLE IN ALL SIZES

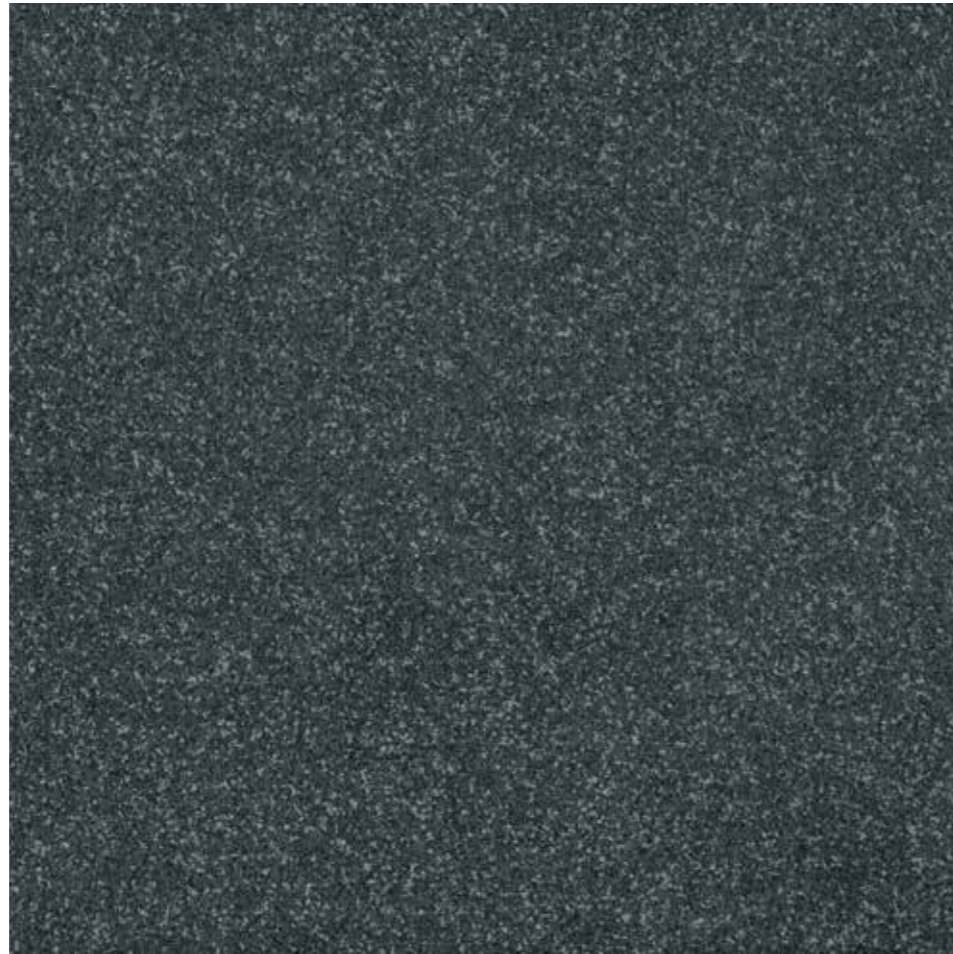

STRUCTURES

AVAILABLE FOR SIZES 12"x12" AND 8"x8"

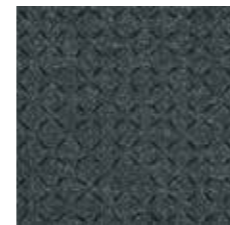
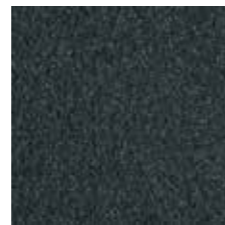

SAND

ROCKS

SQUARE

BUMPS

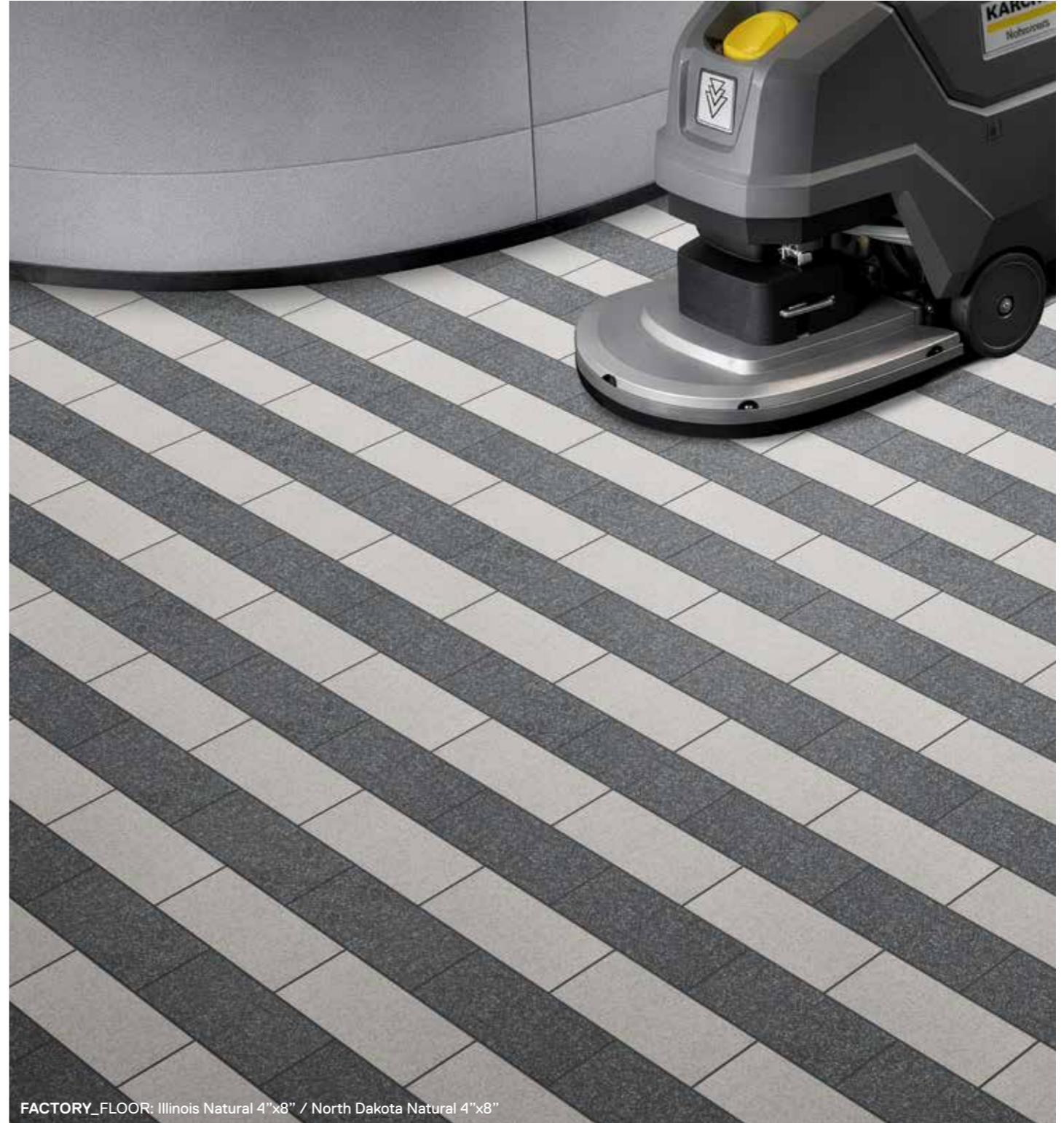

FACTORY_FLOOR: Illinois Natural 4"x8" / North Dakota Natural 4"x8"

FACTORY

COLORADO

SIZES

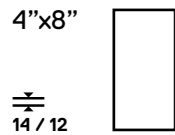
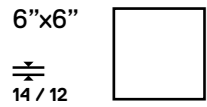
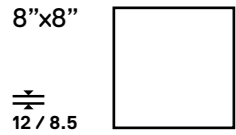
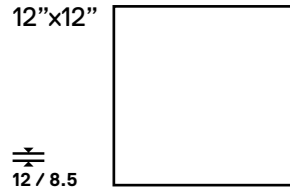

NATURAL

AVAILABLE IN ALL SIZES



STRUCTURES

AVAILABLE FOR SIZES 12"x12" AND 8"x8"



SAND

ROCKS

SQUARE

BUMPS

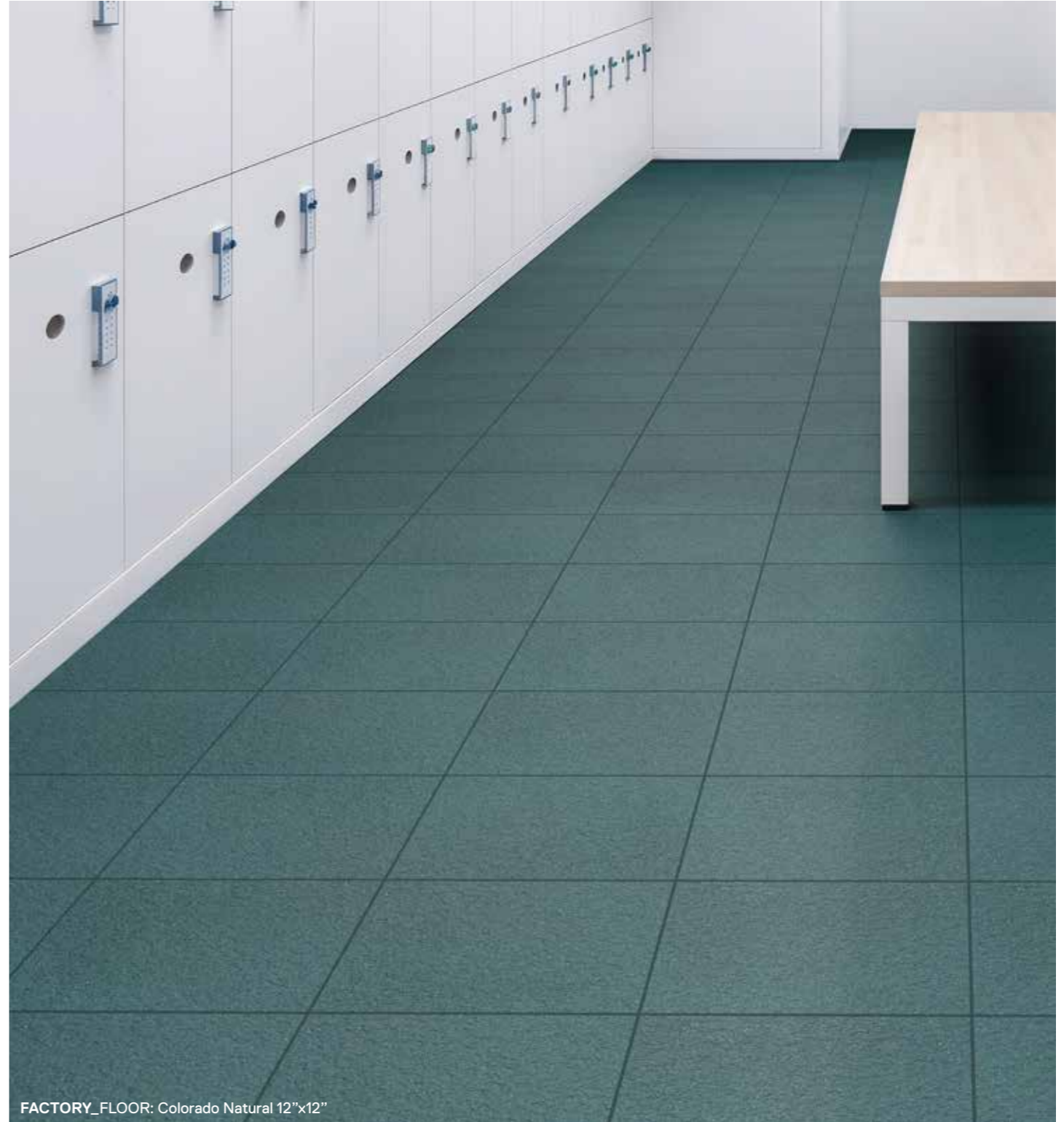





FACTORY_FLOOR: Colorado Natural 12"x12"

04 TECHNICAL SPECIFICATIONS

PRODUCT RANGE

Tecnoker’s porcelain tile range is organized by format, thickness, and surface structure to address a wide spectrum of technical performance requirements. The table below outlines the available configurations, making it easy to match specific commercial needs with the most suitable size and finish.

		THICKNESS	NATURAL	BUMPS	ROCKS	SAND	SQUARE
	12"x12"	8.5 mm	■	■	■	■	■
		12 mm	■	■	■	■	■
	8"x8"	8.5 mm	■	■	■	■	■
		12 mm	■	■	■	■	■
	6"x6"	12 mm	■	-	-	-	-
		14 mm	■	-	-	-	-
	4"x8"	12 mm	■	-	-	-	-
		14 mm	■	-	-	-	-

Available in all colors.

TRIM TILES

Tecnoker special pieces complete the installation with a coordinated solution for edges, corners, and transitions. Cove base, corners, stair treads, and bullnose elements are designed to maintain continuity, support hygiene, and ensure consistent performance.

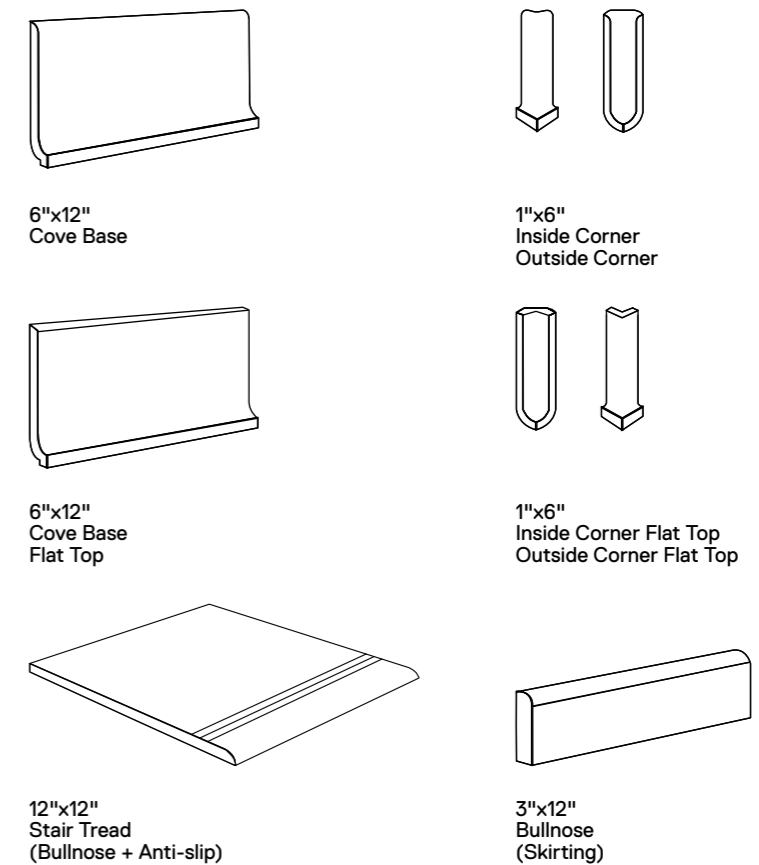

Available in all colors.

TECHNICAL SPECIFICATIONS

	TEST METHOD	REQUESTED VALUE	AVERAGE TEST RESULT	
American National Standard Test Method for measuring dynamic coefficient of friction on hard surface flooring materials	DRY	ANSI A326.3-2021	> 0.42	between : 0.6 and 0.75
American National Standard Test Method for measuring dynamic coefficient of friction on hard surface flooring materials	WET	ANSI A326.3-2021	> 0.42	between : 0.55 and 0.65
Facial Dimensions (mm)	ISO 10545-2	Nominal Size ≥7cm, <15 cm: ±0.9 mm Nominal size ≥ 15 cm: ±2.0 mm Whichever is less	+/- 1 MM	
Thickness (mm)	ISO 10545-2	Nominal Size ≥7cm, <15 cm: ±0.5 mm Nominal size ≥ 15 cm: ±0.5 mm Whichever is less	+/- 0.3 MM	
Straightness of Sides (mm)	ISO 10545-2	Nominal Size ≥7cm, <15 cm: ±0.8 mm Nominal size ≥ 15 cm: ±1.5 mm Whichever is less	+/- 0.1 MM	
Rectangularity (mm)	ISO 10545-2	Nominal Size ≥7cm, <15 cm: ±0.8 mm Nominal size ≥ 15 cm: ±2.0 mm Whichever is less	+/- 0.3 MM	
Warpage (mm)	ISO 10545-2	Nominal Size ≥7cm, <15 cm: ±0.8 mm Nominal size ≥ 15 cm: ±2.0 mm Whichever is less	+/- 0.5 MM	
Water Absorption (%)	ISO 10545-3-2018	</=0.5%	0.30%	
Standard Test Methods for Determination of Water Absorption and Associated Properties by Vacuum Method for Pressed Ceramic Tiles and Glass Tiles and Boil Method for Extruded Ceramic Tiles and Non-tile Fired Ceramic Whiteware Products	ASTM C373	</=0.5%	0.20%	
Determination of Modulus of Rupture and Breaking Strength	ISO 10545-4	Thickness > 7.5mm : min >1300 N	Compliant	
Deep Abrasion Resistance	ISO 10545-6	Maximum 175 mm3	124.7 MM3	
Thermal Shock Resistance of Glazed Ceramic Tile	ISO 10545-9	No Visible Defects	Compliant	
Determination of Chemical Resistance	ISO 10545-13	Minimum requirement B	A	
Determination of Resistance to Stains	ISO 10545-14	Minimum class requirement 3	5	
Standard Test Method for Measuring the Resistance of ceramic and glass tile to freeze-Thaw Cycling	ASTM C1026-13 (2018)	Weight loss <0.5%	No visible damage. Weight loss average: 0.06%	
Standard Test Method for Breaking Strength of Ceramic Tile (floor porcelain tile)	4"x8"	ASTM C648-20	Compliant	
	6"x6"	ASTM C648-20	The average breaking strength shall be 275 lbf or greater with no individual specimen below 250 Lbf	Compliant
	8"x8"	ASTM C648-20	Compliant	
	12"x12"	ASTM C648-20	Compliant	
Frost Resistance	EN ISO 10545-12		Resistant	

PACKING

Nominal Size	Thickness	Pieces/Box	Sqft/Box	Boxes/Pallet	Sqft/Pallet	Lbs/Pallet	Lbs/Boxes	Lbs/Sqft
12"x12" Natural	8.5 mm	12	12.00	48	576.00	1968	41	3.42
12"x12" Natural	12 mm	8	8.00	48	384.00	1968	41	5.13
12"x12" Structured	8.5 mm	12	12.00	48	576.00	1968	41	3.42
12"x12" Structured	12 mm	8	8.00	48	384.00	1968	41	5.13
8"x8" Natural	8.5 mm	33	14.65	52	761.90	2704	52	3.55
8"x8" Natural	12 mm	23	10.21	52	531.02	2704	52	5.09
8"x8" Structured	8.5 mm	33	14.65	52	761.90	2704	52	3.55
8"x8" Structured	12 mm	23	10.21	52	531.02	2704	52	5.09
6"x6" Natural	12 mm	26	6.50	64	416.00	2240	35	5.38
6"x6" Natural	14 mm	22	5.50	64	352.00	2240	35	6.36
4"x8" Natural	12 mm	44	9.77	52	507.94	2704	52	5.32
4"x8" Natural	14 mm	38	8.44	52	438.67	2704	52	6.16
3"x12" Bullnose (Skirting)	8.5 mm	15	3.75	85	318.75	1360	16	4.27
6"x12" Cove base	8.5 mm	20	10.00	64	640	1920	30	3.00
1"x6" Inside corner	8.5 mm	8	-	85	-	127.5	1.5	-
1"x6" Outside corner	8.5 mm	8	-	85	-	127.5	1.5	-
6"x12" Cove base flat top	8.5 mm	10	5.00	112	560	3360	30	6.00
1"x6" Inside corner flat top	8.5 mm	8	-	85	-	127.5	1.5	-
1"x6" Outside corner flat top	8.5 mm	8	-	85	-	127.5	1.5	-
12"x12" Stair tread (bullnose + anti-slip)	12 mm	8	8.00	48	384	1968	41	5.13

TECHNICAL DATA: Approximate weights Lbs/Sqft

**PORCELAIN TILE SURFACES FOR
TECHNICAL SPACES ENGINEERED
AND MANUFACTURED IN THE U.S.A.**



TECNOKER

980 Alfred Thun Rd.
Clarksville, TN 37040

Sales Office

Tel +1 (931) 919 2066
info@tecnoker.com
www.tecnoker.com